

**MATERIAL:**

CYLINDER: STEEL  
TROLLEY : STEEL  
VALVE : BRASS HOT STAMPING.

**COATING:**

TROLLEY : RED RAL 3000  
CYLINDER: INTERNAL AND EXTERNAL SHOT BLASTING  
FINAL COATING RED RAL 3000  
RESISTANCE TESTS ACCORDING  
ISO 9227 & ISO 2409

FIRE RATING : 183B  
CAPACITY : 20 kg  
HOSE LENGTH : 5m  
MIN DISCHARGE TIME : 49 s  
DISCHARGE RANGE : 3 m  
TEST PRESSURE : 300 bar  
WORKING PRESSURE : 176 bar  
CLASS : B  
DESIGN STANDARD : APPROVAL BV;  
EN 1866-1; MED; PED  
CCS; RMRS

**WEIGHT:**

EMPTY : 60 kg  
FULL : 80 kg

TEMPERATURE OF USE : -30°C and +60°C

WHEELED DIAMETER :  $\varnothing$  300mm

**USE ON VOLTAGE OVER 1000V. UP TO 35 Kv ACCORDING  
TO LABEL INSTRUCTION ON FIRE EXTINGUISHER**

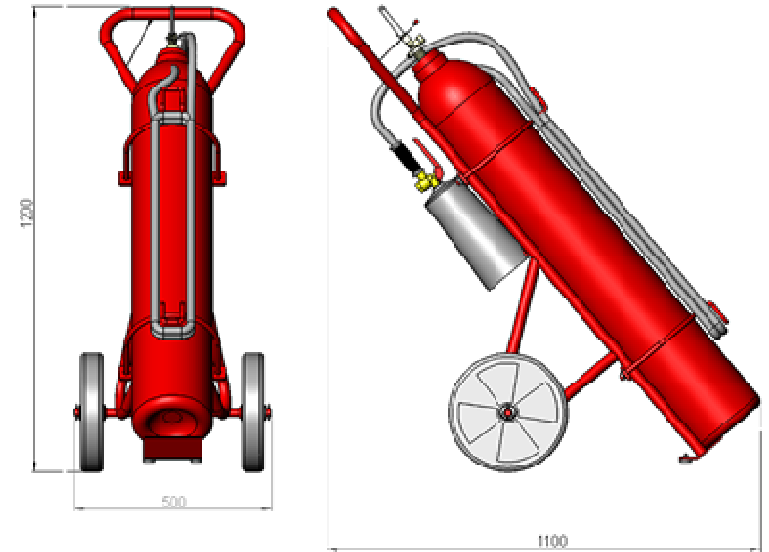
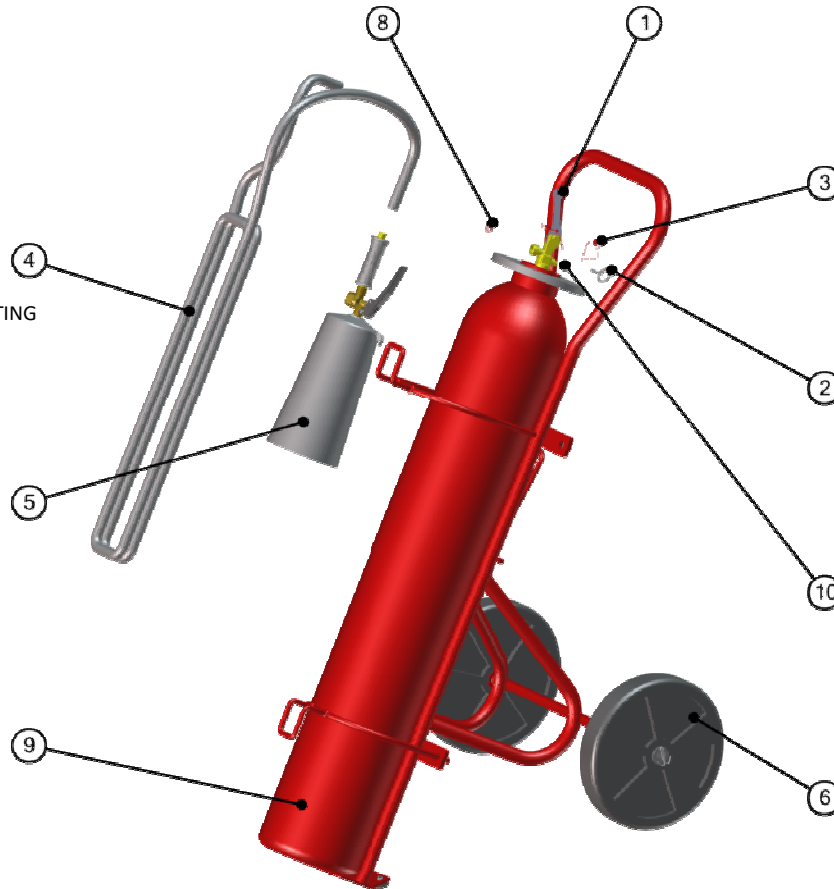

**Survitec**  
**FIRE EXTINGUISHER**  
20 kg CARBON DIOXIDE  
183B

1. Remove the horn. Uncoil the hose.
2. Remove safety pin. Press the CO<sub>2</sub> valve lever down fully.
3. Direct the horn at base of flames.

Avoid any direct contact of the nozzle with electrical conductors. In case of use on voltage over 1000 V, keep nozzle at a minimum distance of 0.5m. This fire extinguisher is acceptable to use on voltage over 1000V by authorized staff according to regulations in force, provided that following distances are respected:  
- Up to 20 kV : keep nozzle at minimum distance of 1 m.  
- From 20 kV to 35 kV : keep nozzle at minimum distance of 2 m.  
Do not expose to source of heat.

**U20C**

Survitec Group Limited  
15 Broadford Road, Broadford, Shropshire, UK, CH41 1HQ  
Tel: +44 (0)1542 84621, Email: info@survitecgroup.com  
Website: www.survitecgroup.com  
Manufacturer: Survitec Group

10	1	Bursting disk F/CO2 ext. and cyl. 500 pck	674192
9	1	CO2 cylinder 22 kg W/valve w/o hose and horn	668384
8	1	Fibre seal F/CO2 ext. And cyl. Valve connection 25pck	667824
7	1	Label F/U20C MED 10 pck	768762
6	2	Wheel w/safety pin and washer F/E45A2/P25/P25P/P50/P50P/U9C/U20C/U22C	667790
5	1	CO2 nozzle F/All wheeled CO2 ext	669010
4	1	Discharge hose F/All wheeled CO2 ext	669028
3	1	Wire and seal F/All ext. 90 pck	667600
2	1	Safety pin F/All wheeled ext./U5C 10 pck	667683
1	1	Valve F/All wheeled CO2 ext.	668129

ITEM	NO OF	DESCRIPTION	PROD NO
------	-------	-------------	---------



02	Drawn by/date MB 01/12/2017
	Issued by/date MB 01/12/2017
Rev no.	Approved by/date

Main product group or System

**SURVITEC PORTABLE FIRE  
FIGHTING EQUIPMENT**

Product

**CO2 EXTINGUISHER 20 KG  
WHEELED MODEL U20C**

Product no. 767930

Data sheet no.  
**29-02-020**